



Snake
bracieri a gas
gas fire logs

guida all'installazione
installation guide

INDICE INDEX

Combustione naturale <i>Natural combustion</i>	04
Installazione Tipo A e B <i>Type A and B installation</i>	05
Modalità di installazione <i>Installation mode</i>	06
Rivestimento <i>Casing</i>	07
Vetro di protezione <i>Protection glass</i>	08
Scarico fumi <i>Exhaust fumes</i>	09
Installazione secondo UNI7129 <i>UNI7129 installation</i>	10
Recupero di un camino a legna esistente <i>recovery of an existing wood fireplace</i>	11
Alimentazione elettrica e gas <i>power supply and gas</i>	12
Personalizzazioni <i>customizations</i>	14
Accessori <i>Accessories</i>	15
Dotazioni e dimensioni <i>Dimensions and equipped</i>	16
Dati tecnici <i>data table</i>	17



L'unico camino a gas progettato e costruito in Italia
il riscaldamento domestico ed industriale sin dagli anni 70
apparecchi a gas tutti **made in italy**



bracieri a gas · *gas fire logs*

Snake

canna fumaria

flue

Ø 180 MIN



ingresso aria comburente



uscita fumi combustione

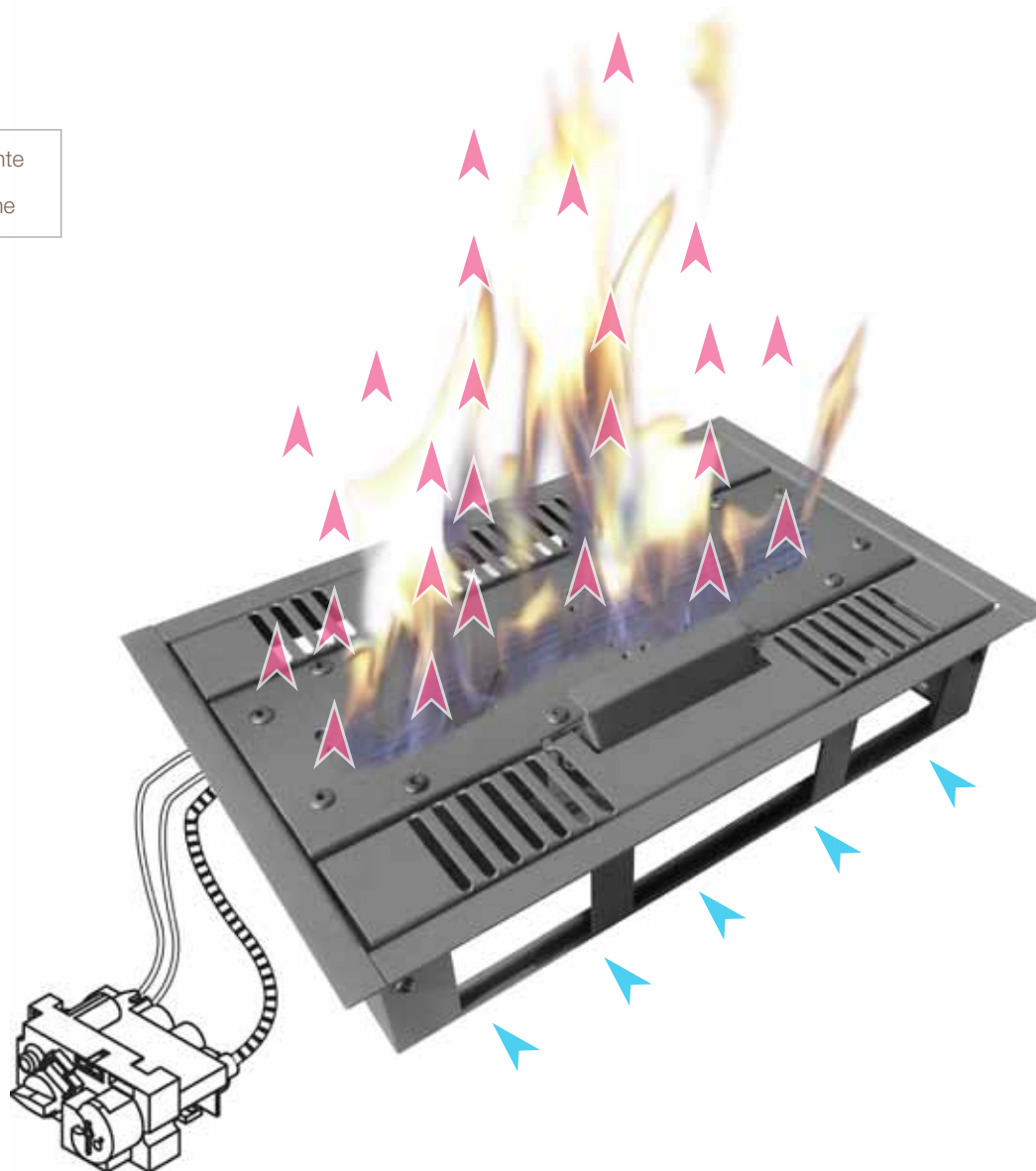

A) installazione all'interno, ambiente chiuso con canna fumaria.

B) installazione all'aperto, senza tetto.

C) installazione all'aperto, senza due pareti attigue.

D) installazione all'aperto, senza due pareti opposte.

E) installazione all'aperto, con almeno il 25% della superficie aperta.

F) installazione all'aperto.

A) installation inside, enclosed chimney area.

B) outdoor, roofless installation.

C) outdoor installation without two adjacent walls.

D) outdoor installation, without two opposite walls.

E) Outdoor installation, with at least 25% of the open surface.

F) outdoor installation.

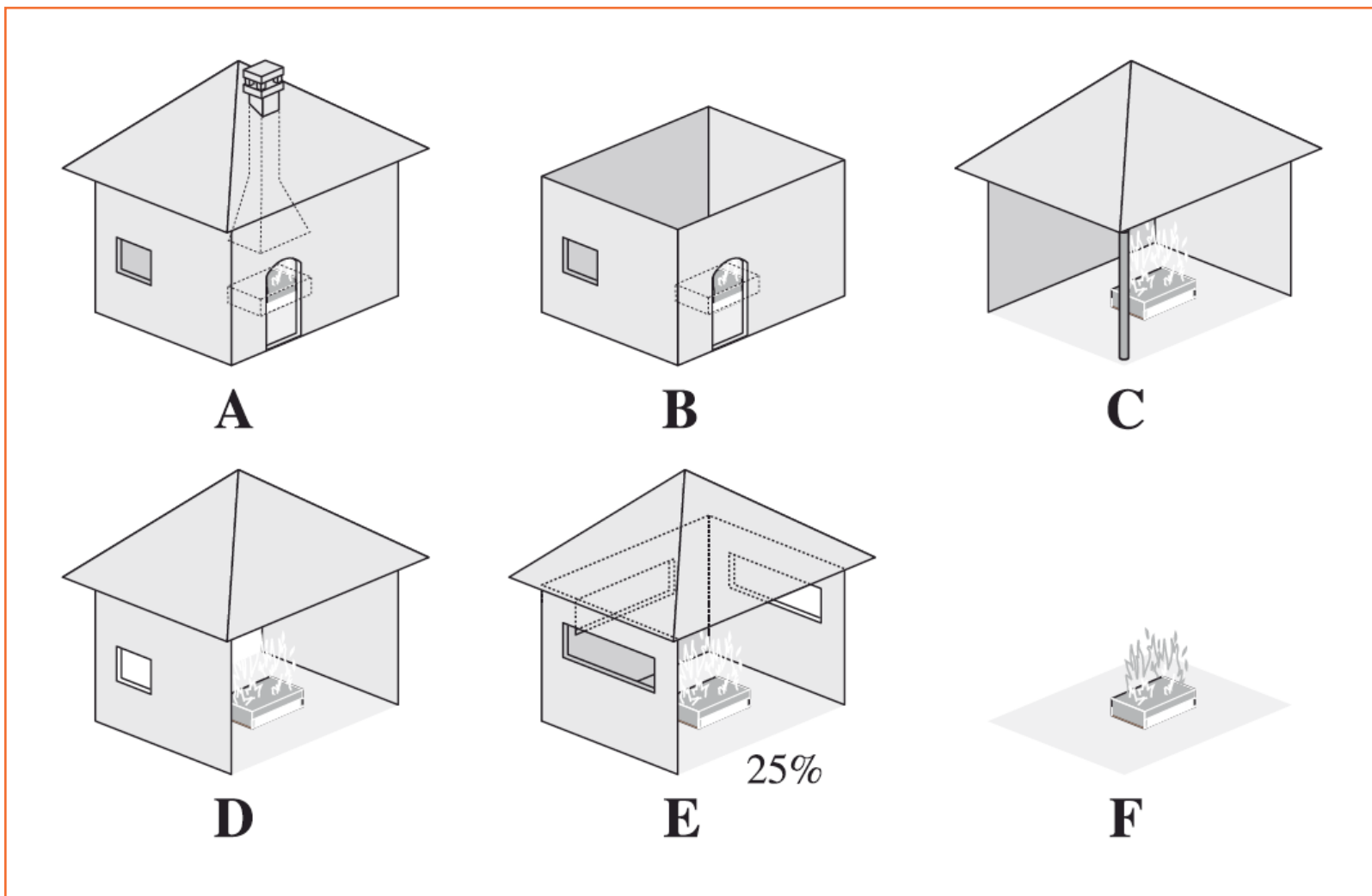

INSERTO
insert

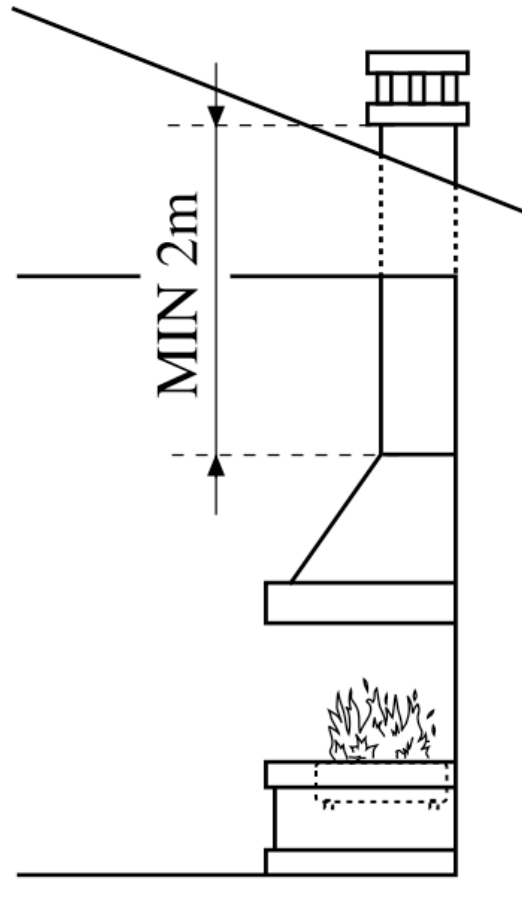

INCASSATO nel piano
INSERTED in the plan

NON CI SONO DISTANZE MIN DA RISPETTARE TRA L'APPARECCHIO E TUTTE LE PARETI CHE DELIMITANO IL VANO.

THERE IS NO MINIMUM DISTANCE BETWEEN THE APPLIANCE AND ALL THE WALLS DEFINING THE COMPARTMENT.

LA CAPPA (7) DEV'ESSERE SEMPRE PIÙ GRANDE RISPETTO ALL'APPARECCHIO.
NOTA: POSIZIONARE L'APPARECCHIO SEMPRE SOTTO LA CAPPA.

THE HOOD (7) MUST BE LARGER THAN THE APPLIANCE.
NOTE: ALWAYS PLACE THE APPLIANCE UNDER THE HOOD.

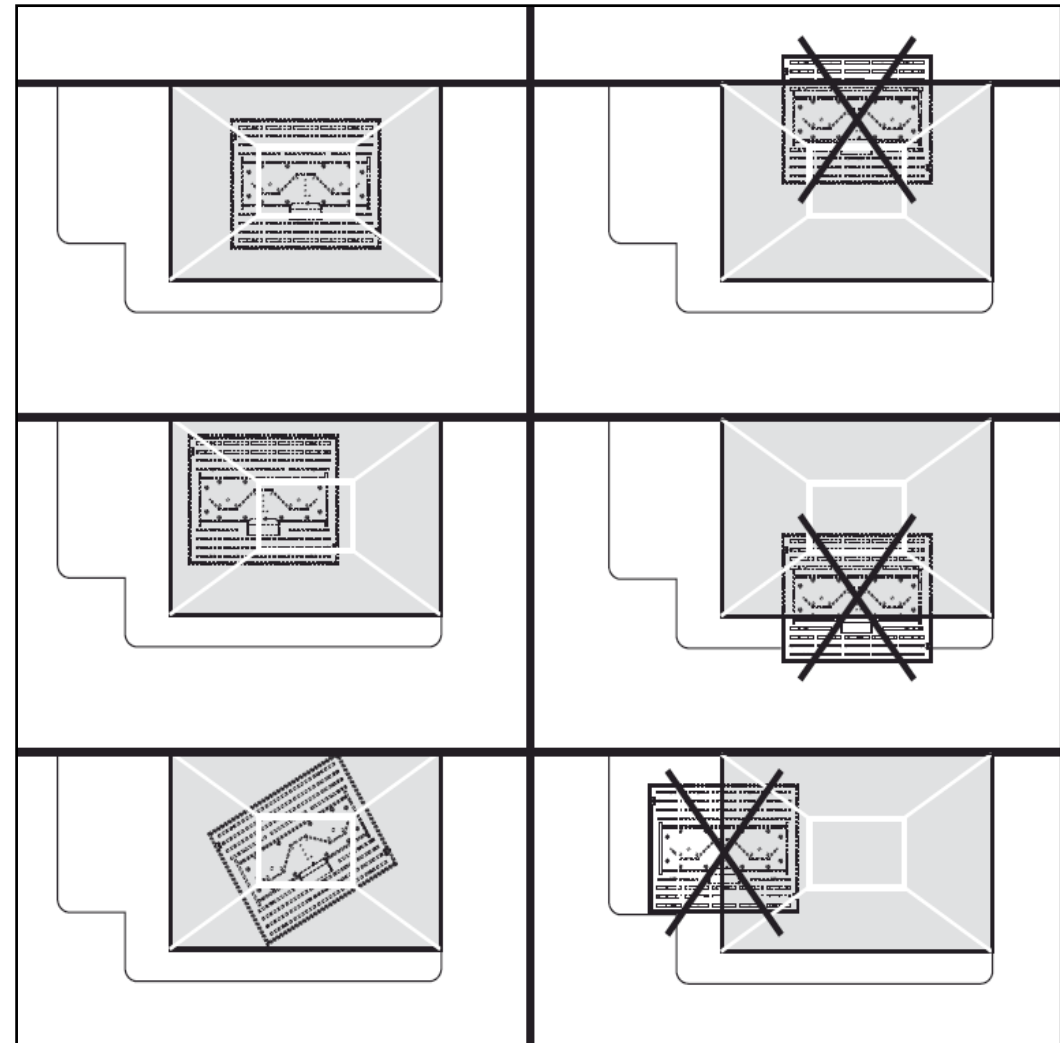
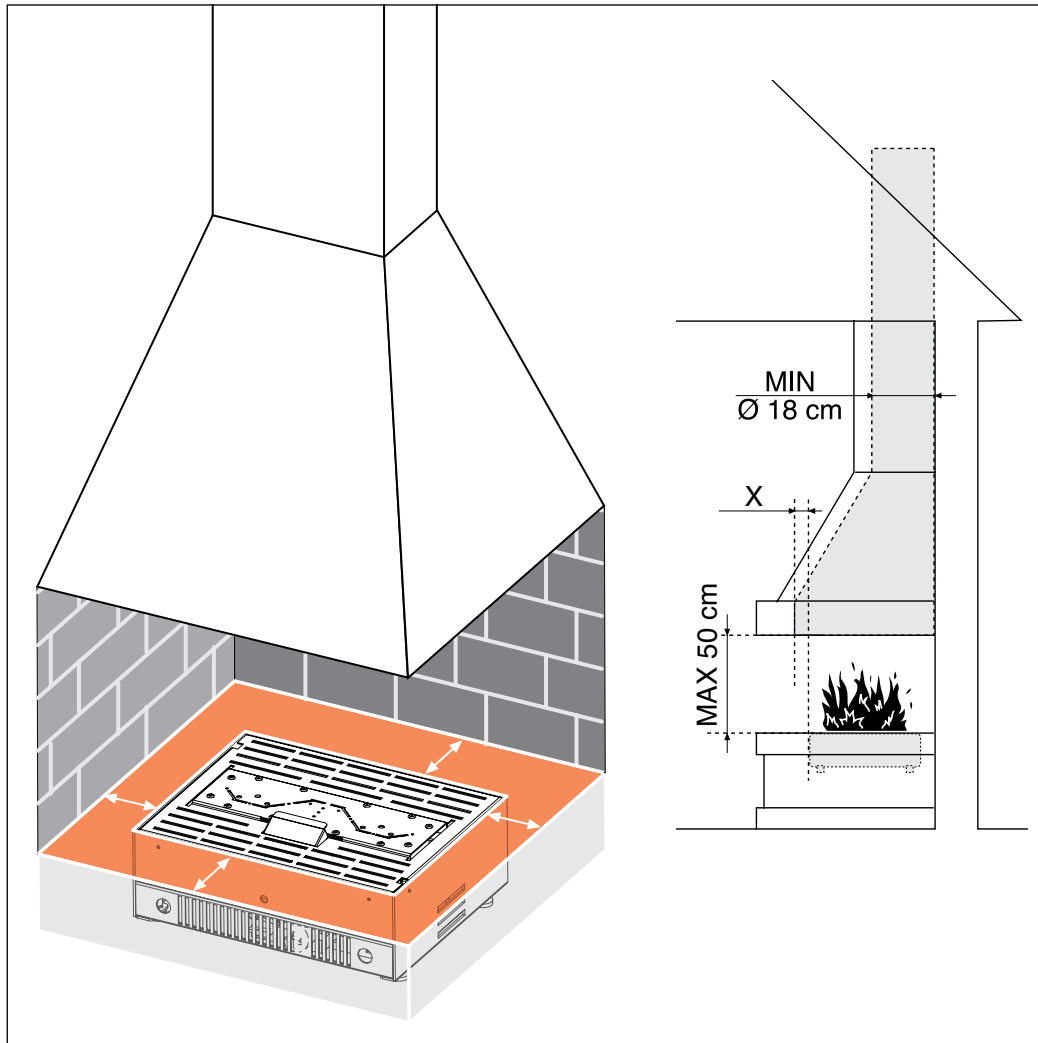

SE SI DESIDERA INSTALLARE UN VETRO DI PROTEZIONE ATTORNO ALL'APPARECCHIO, PER IL SUO CORRETTO FUNZIONAMENTO OCCORRE MANTENERE UNA **DISTANZA MIN DI 10cm DAL PIANO DEL FUOCO AL BORDO INFERIORE DEL VETRO.**

IF YOU WANT TO INSTALL A PROTECTIVE GLASS AROUND THE APPLIANCE, IT IS NECESSARY TO MAINTAIN A **MINIMUM DISTANCE OF 10 cm FROM THE FIRE TOP TO THE BOTTOM EDGE OF THE GLASS FOR PROPER OPERATION.**

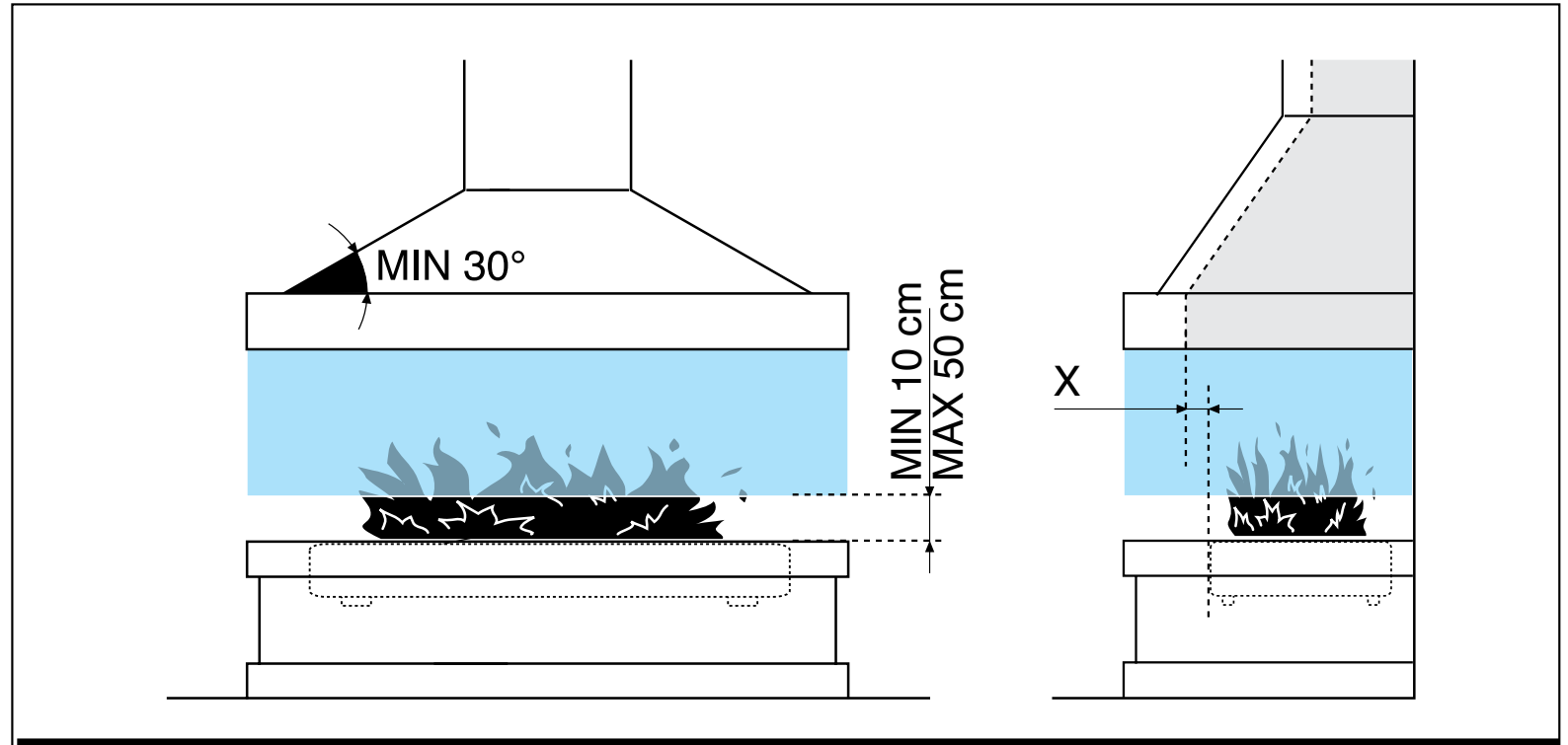
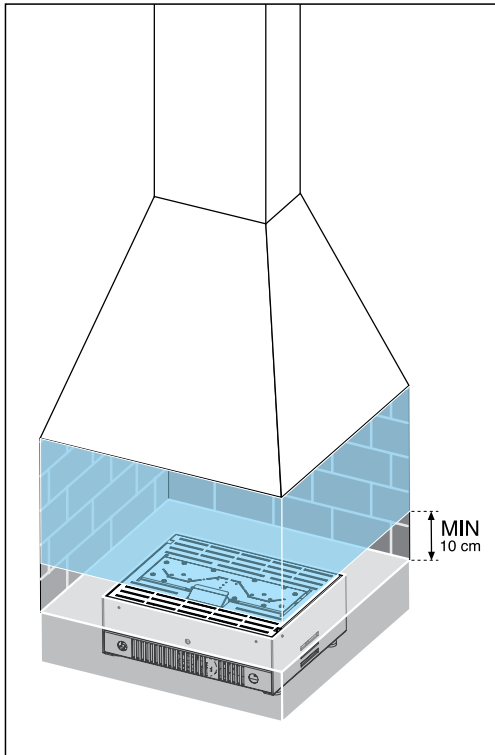

CANNA FUMARIA NUOVA: DEVE RISPETTARE TUTTE LE DIMENSIONI MINIME RICHIESTE DA ITALKERO E PER GARANTIRE IL CORRETTO FUNZIONAMENTO DELL'APPARECCHIO SI CONSIGLIA L'UTILIZZO DI ESTRATTORI IN CASO DI PERCORSI TORTUOSI.

NEW SMOKE DUCT: MUST ALWAYS ALL MINIMUM DIMENSIONS REQUIRED BY ITALKERO AND TO ENSURE THE CORRECT OPERATION OF THE APPLIANCE WE RECOMMEND THE USE OF EXTRACTORS IN THE CASE OF WINDING PATHS.

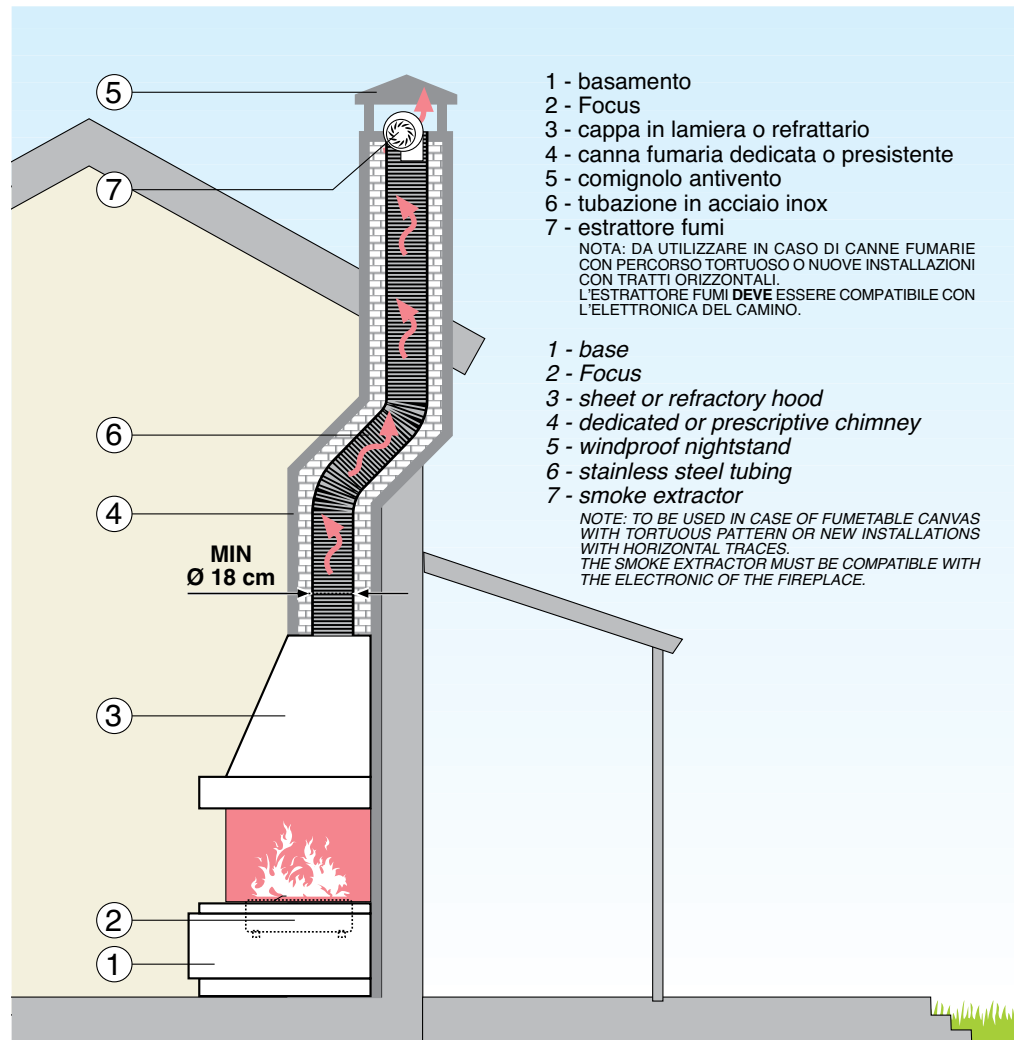

CANNA FUMARIA ESISTENTE: DEVE RISPETTARE TUTTE LE DIMENSIONI MINIME RICHIESTE DA ITALKERO, PER GARANTIRE IL CORRETTO FUNZIONAMENTO DELL'APPARECCHIO.

NOTA: RIMUOVERE L'EVENTUALE VALVOLA FUMI.

EXHAUST SMOKE OUTLET ALREADY IN PLACE: MUST RESPECT ALL MINIMUM DIMENSIONS REQUIRED BY ITALKERO, TO ENSURE THE CORRECT OPERATION OF THE APPLIANCE.

NOTE: REMOVE THE EVENT WHEEL VALVE.

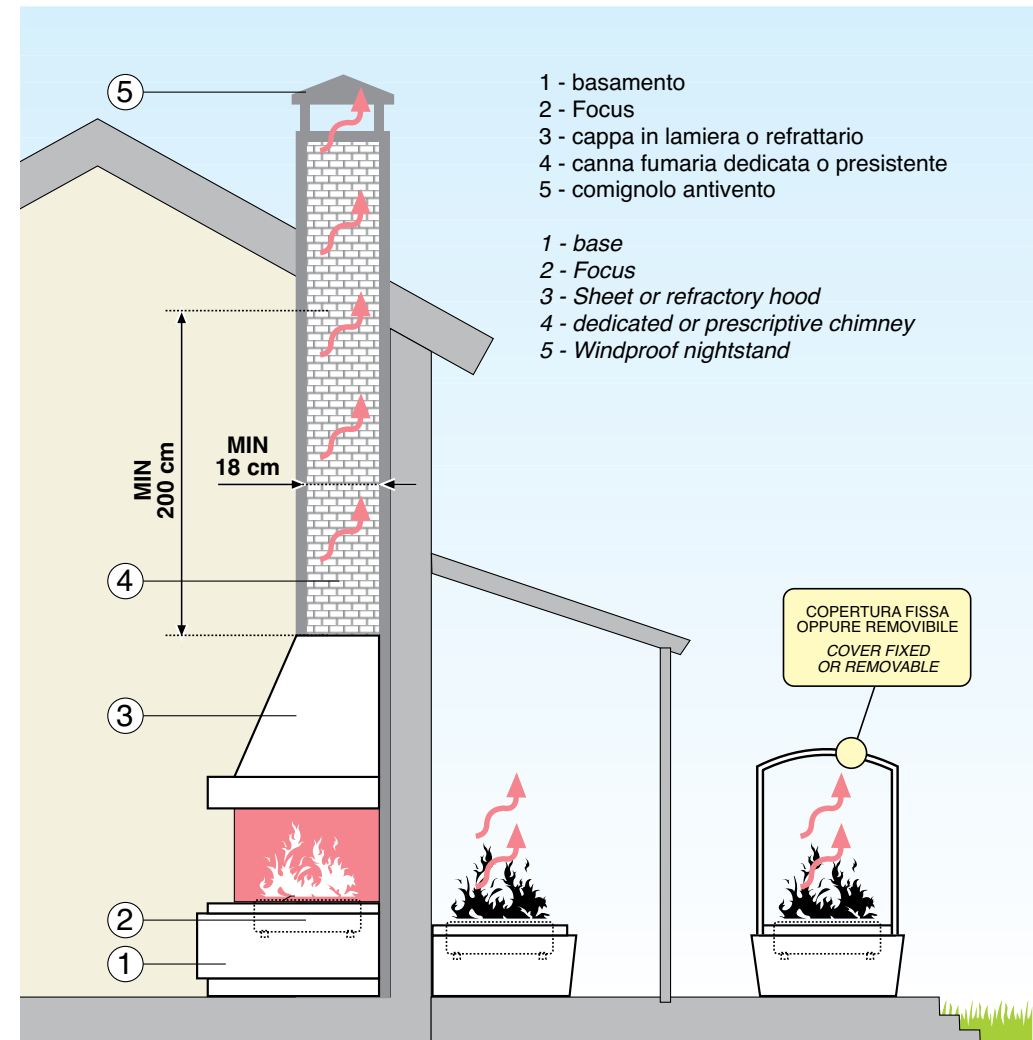

LA NORMA **UNI7129** PREVEDE UNA PRESA D'ARIA ESTERNA DI 6 cm² PER OGNI KW DI POTENZA INSTALLATO NELL'AMBIENTE.

NOTA: L'APERTURA NON DEVE MAI ESSERE INFERIORE A 100cm²

THE STANDARD **UNI7129** PROVIDES AN OUTDOOR AIR INTAKE OF 6 cm² PER KW OF INSTALLED POWER IN THE ENVIRONMENT

NOTE: THE OPENING MUST NEVER BE LESS THAN 100cm².

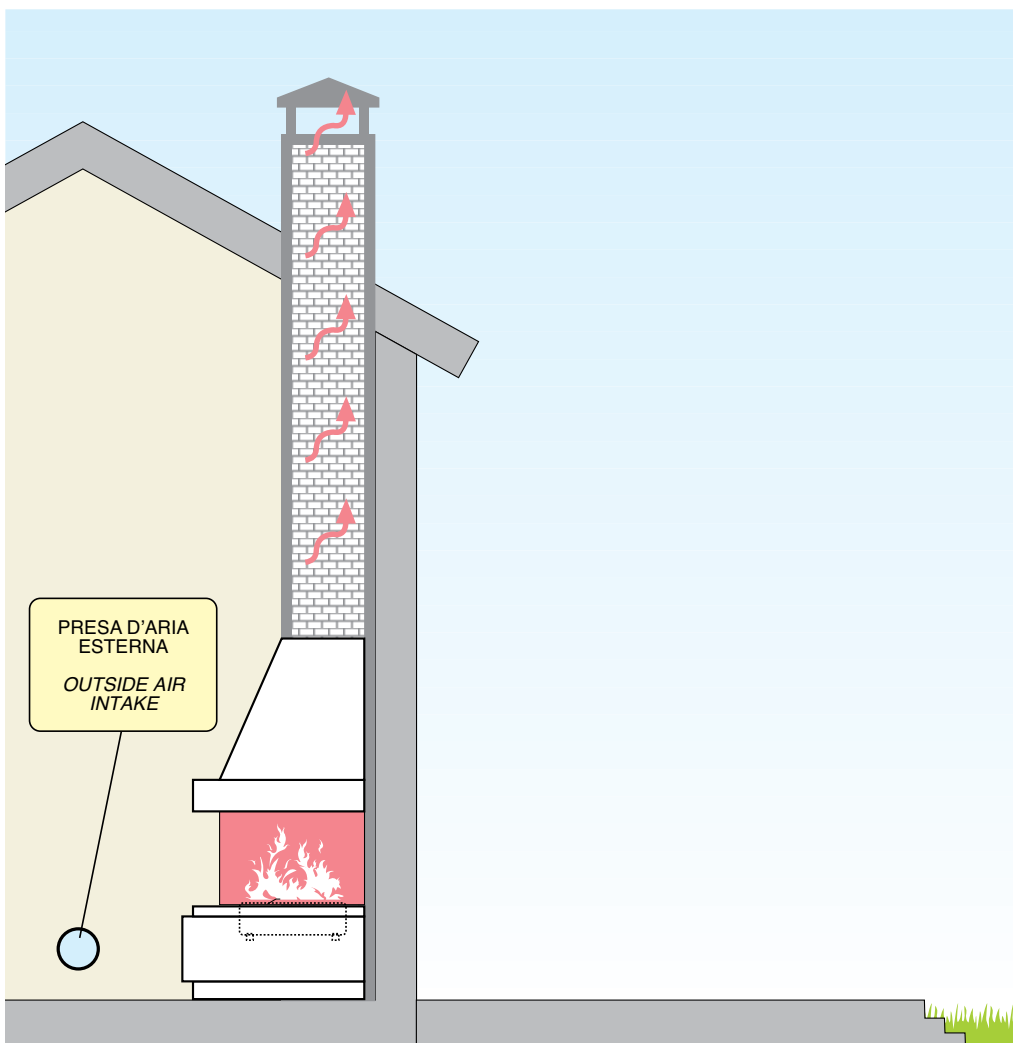

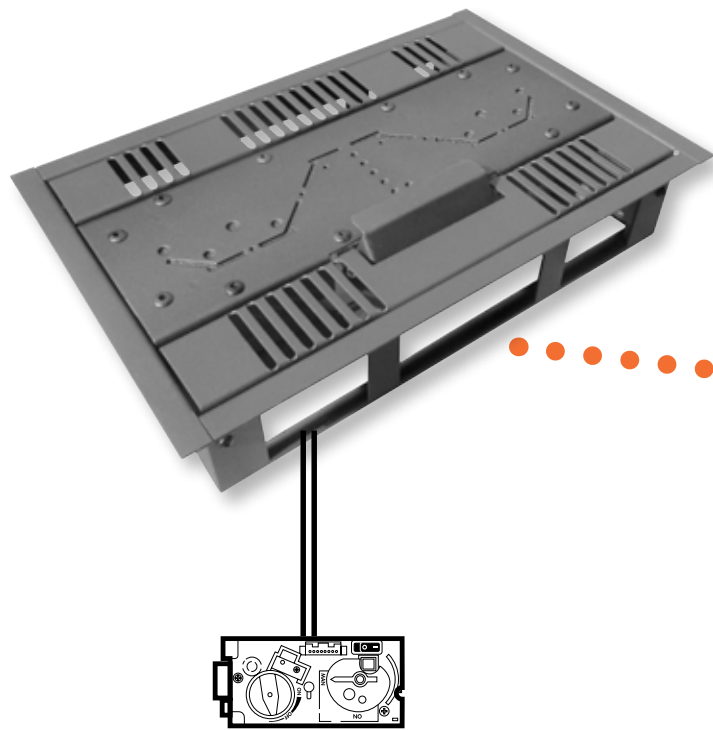

GAS

VALVOLA GAS:

- 7 - PROVA PRESSIONE IN USCITA
- 8 - PROVA PRESSIONE IN ENTRATA
- 10 - INGRESSO ALIMENTAZIONE GAS
(3/8" - Ø 10mm)

NOTA: PREVEDERE RUBINETTO CHIUSURA GAS A MONTE DELLA VALVOLA.

NOTA PER FOCUS: NELLA VERSIONE AD INCASSO USARE SEMPRE UN TUBO GAS FLESSIBILE.

GAS VALVE:

- 7 - OUTPUT PRESSURE TEST
- 8 - INLET PRESSURE TEST
- 10 - GAS SUPPLY INPUT
(3/8" - Ø 10mm)

NOTE: PROVIDE GAS SHUT-OFF VALVE TAP.

NOTE FOR FOCUS: IN THE FLUSH VERSION ALWAYS USE A FLEXIBLE GAS HOSE.

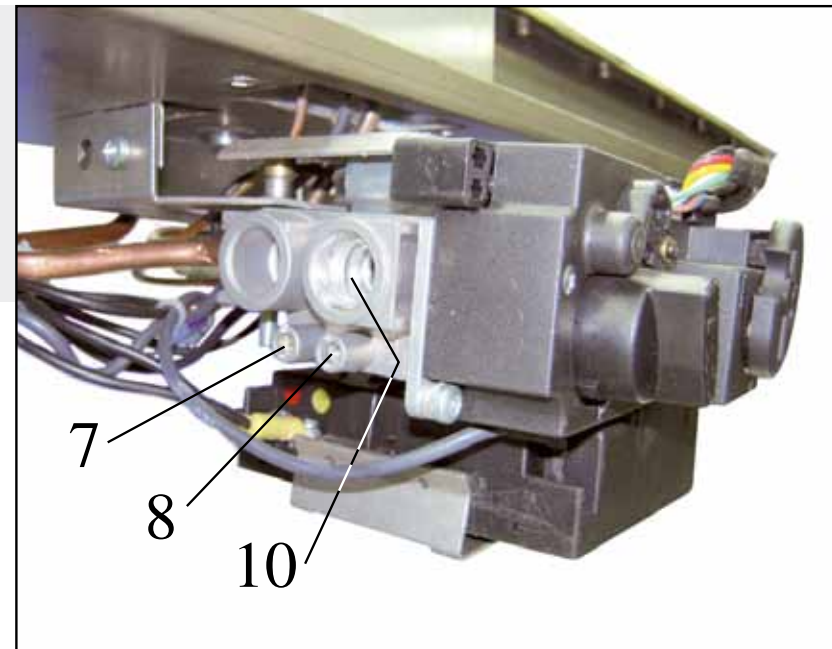

ELETTRICITÀ ELECTRICITY

- 1 - PRESA PER KIT ALIMENTAZIONE ELETTRICA (optional per evitare sostituzione batterie)
- 2 - UNITÀ RICEVENTE

- 1 - POWER SUPPLY KIT ELECTRIC (OPTIONAL TO AVOID BATTERY REPLACEMENT)
- 2 - RECEIVING UNIT

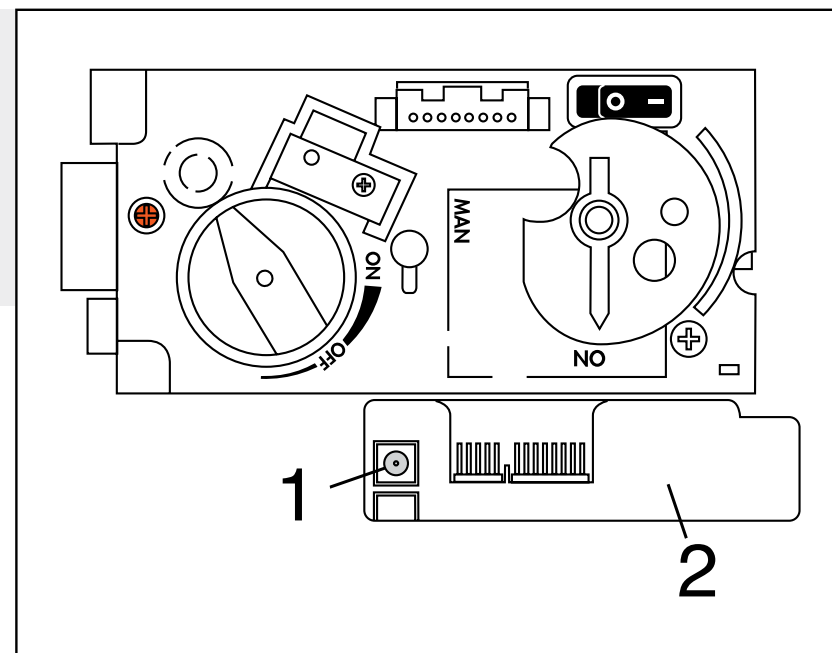

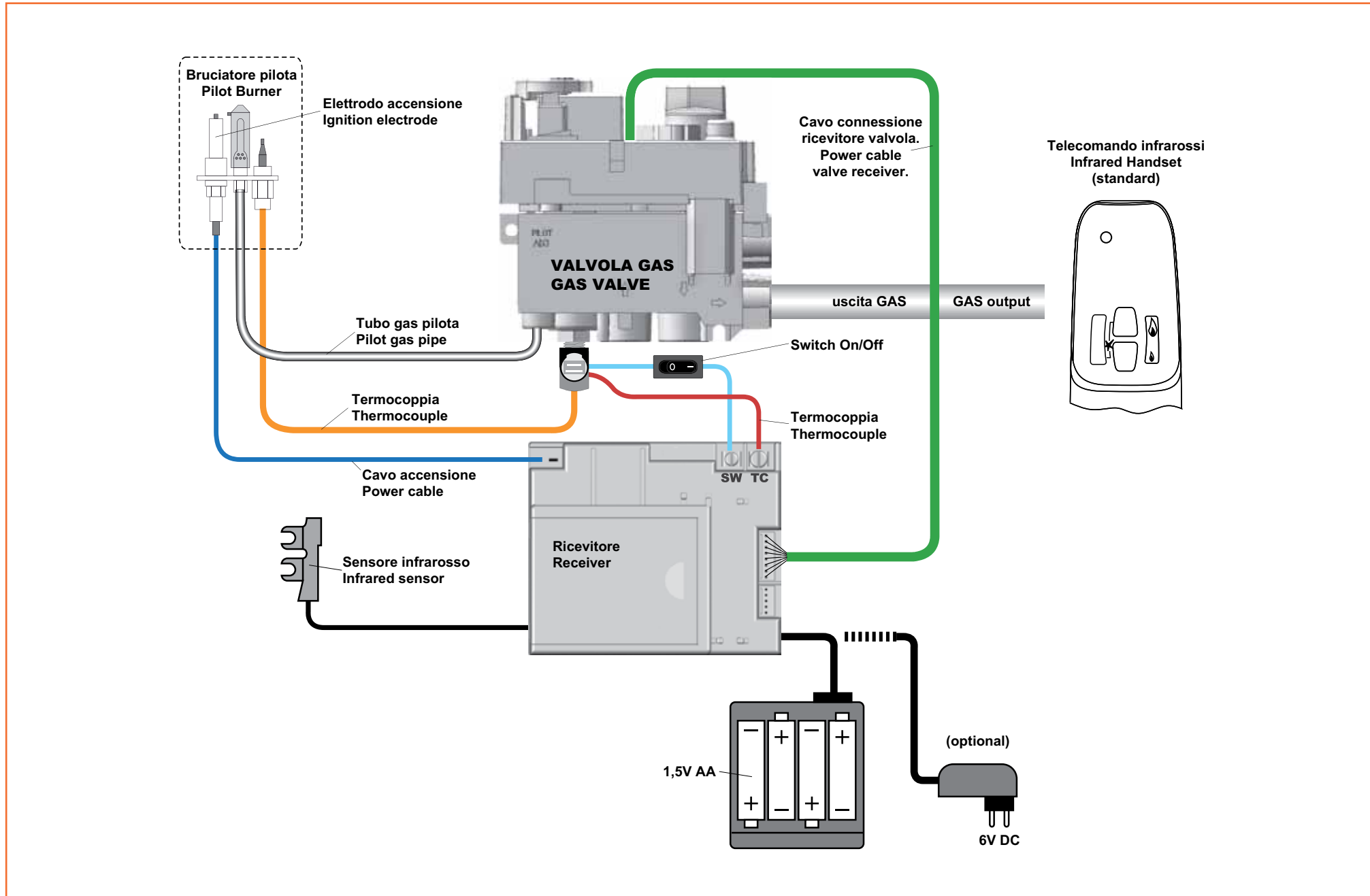

L'ACQUISTO DEL KIT ITALKERO (LEGNA O SASSI) ED IL SUO CORRETTO POSIZIONAMENTO GARANTIRE LA QUALITÀ E LA BELLEZZA DELLA FIAMMA.

NOTA: UTILIZZARE SOLTANTO ACCESSORI E RICAMBI ORIGINALI DEL COSTRUTTORE, L'UTILIZZO DI PARTI NON ORIGINALI COMPORTA L'IMMEDIATA DECADENZA DELLA GARANZIA, POSSONO INOLTRE RISULTARE PERICOLOSI O DANNEGGIARE L'APPARECCHIO STESSO.

THE PURCHASE OF THE ITALKERO (WOOD OR STONE) KIT AND ITS CORRECT POSITIONING GUARANTEE THE QUALITY AND THE BEAUTY OF THE FLAME.

NOTE: USE ONLY ORIGINAL ACCESSORIES AND SPARE PARTS OF THE MANUFACTURER, THE USE OF NON-ORIGINAL PARTS IMPLIES THE IMMEDIATE WARRANTY, MAY ALSO BE DANGEROUS OR DAMAGE THE DEVICE ITSELF.

LEGNA · LOGS



SASSI · PEBBLES

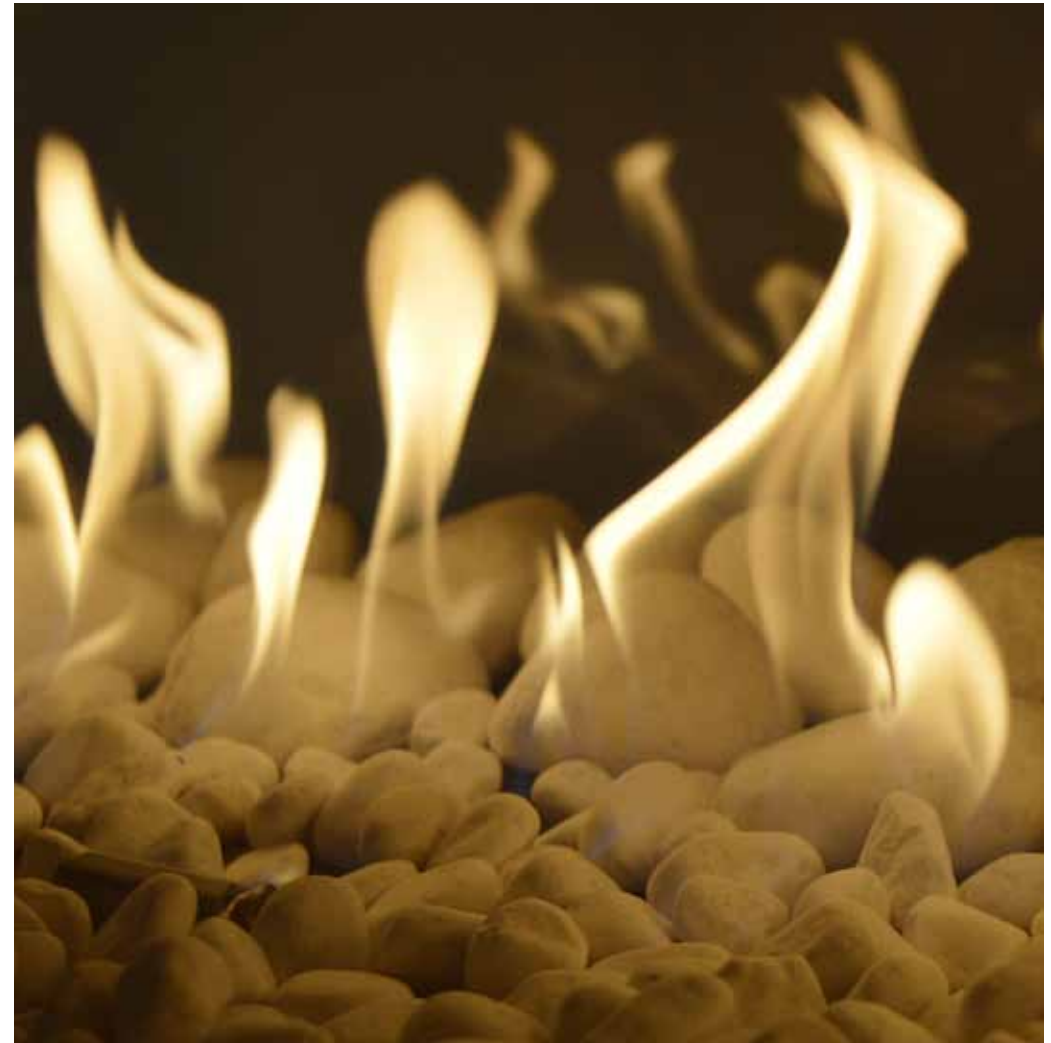



Comando manuale a parete con cavo (L 3m).

Wall manual control with cable (L 3m).

code	model
7000994 00	Focus, Snake, Quadro, K.



Cablaggio connessione estrattore fumi (L 4m).

Wiring connection to gas exhauster.

code	model
70006084 00	Focus, Snake, Quadro, K.



Kit rubinetto collegamento gas (3/8").

KIT gas tap connection (3/8").

code	model
70000996 00	Focus, Snake, Quadro, K.

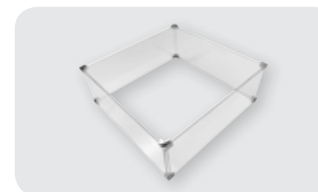

Kit vetri di protezione e antivento.

Protection and wind shield glass kit.

code	model	L x L x h
70006330 00	Focus/Snake 40.	490x400x190
70006331 00	Focus/Snake 60.	610x400x190
70006332 00	Focus/Snake 80.	880x400x190
70006333 00	Focus/Snake 130.	1410x400x190
70006334 00	Quadro 40.	490x490x190



Kit ceppi ceramici con braci.

Log set KIT.

code	model
70006048 00	Focus/Snake 40-60, Quadro.
70006073 00	Focus/Snake/K 80-130.
70006048 00 + 70006073 00	Focus/Snake/K 180.



Kit ceppi ceramici BIG con braci.

BIG log set KIT.

code	modello
70006588 00	Focus/Snake 40-60, Quadro 40.
70006578 00	Focus/Snake/K 80-130.
70006586 00	Focus/Snake/K 180.



Kit ciottoli bianchi di Carrara.

Carrara pebbles KIT.

code	model
70006036 00	Focus/Snake/K 60-80, Quadro.
70006037 00	Focus/Snake 40, Torcia.
70006039 00	Focus/Snake/K 130.
70006103 00	Focus/Snake/K 180.



Portatile esterno (L 1,5m).

External battery holder (L 1,5m).

code	model
70006610 00	Focus.



Kit alimentazione elettrica (3V-35mA), per non sostituire le pile nell'unità ricevente.

Power supply kit (3V - 35mA).

code	model
70006071 00	Focus, Snake, Quadro, Torcia, K.

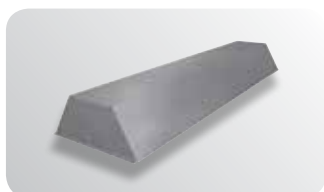

Coperchio anti pioggia per installazione da esterno in acciaio INOX.

INOX stainless steel rain cover for OUTDOOR installation.

code	model	L x L x h
70006508 00	Focus/Snake 40	356x379x152
70006509 00	Focus/Snake 60	356x512x152
70006510 00	Focus/Snake 80	356x780x152
70006511 00	Focus/Snake 130	356x1313x152
70006514 00	Focus/Snake 180	356x1863x152
70006580 00	Quadro 40	441x441x152



Sportellino alloggiamento valvola gas.

Gas valve housing door.

code	model	L x L
70006579 00	Snake, Quadro, K.	320x320

inserti a fiamma libera per uso INTERNO o ESTERNO
gas fire logs for INSIDE or OUTSIDE use



Dotazioni:

- telecomando base a raggi infrarossi (senza display)
- struttura in lamiera zincata verniciata

Equipped:

- standard remote control (with no display)
- galvanized steel and painted structure

Snake40

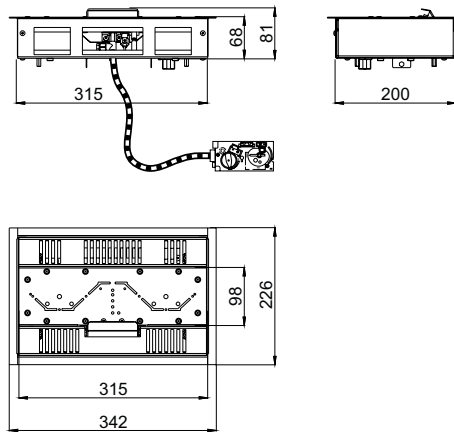

Snake60

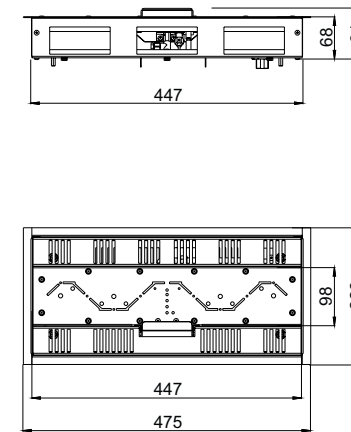

Snake80

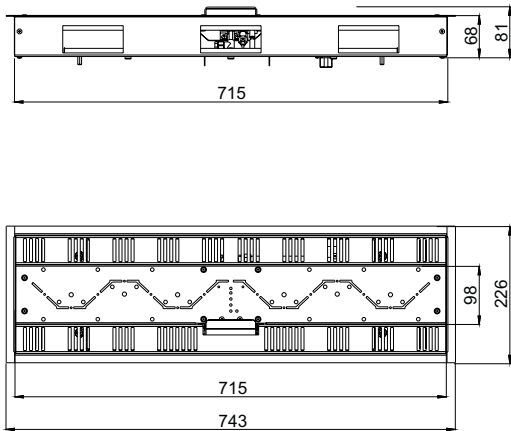

Snake130

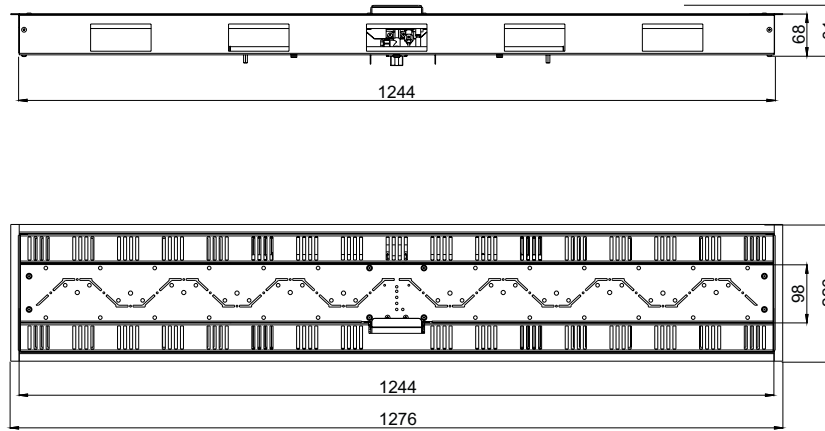

Snake180

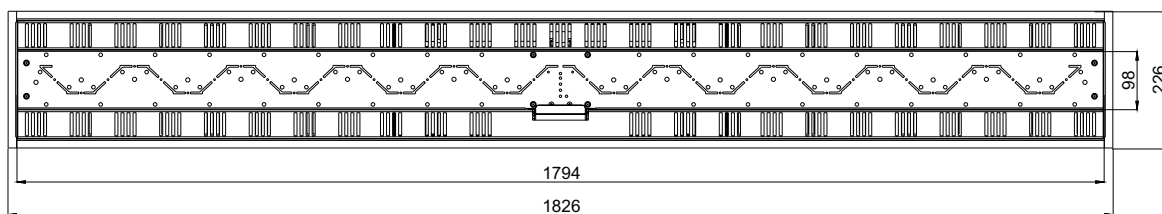
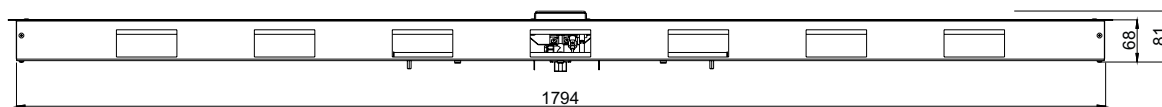

Snake180C

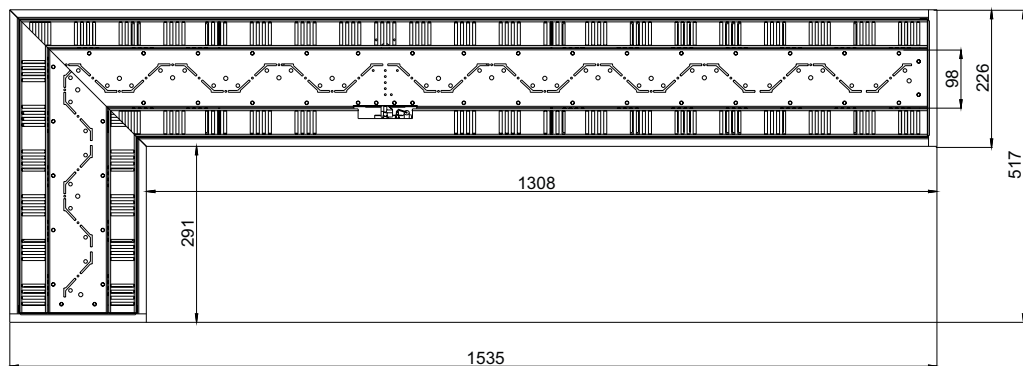
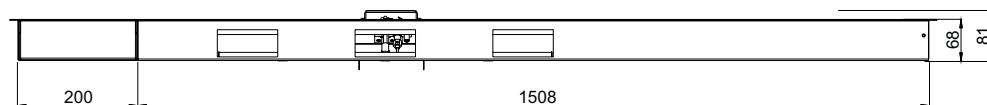

modello model		Snake 40	Snake 60	Snake 80	Snake 130	Snake 180	Snake 180C
Portata max/min Heat input max/min	kW	8,3/3,3	10/4	10/4	12/5	15/8	15/8
Potenza termica nom./rid. Pn Heat output nom./red. Pn	kW	-	-	-	-	-	-
Tipo scarico Exhaust type		B _{IAS}	B _{IAS}	B _{IAS}	B _{IAS}	B _{IAS}	B _{IAS}
Rendimento Efficiency level	%	-	-	-	-	-	-
Efficienza / NOx Efficiency class / NOx	class	4	4	4	5	5	5
Consumo G20 nom./rid. Consumption G20 nom./red.	m³/h	0,878/0,349	1,057/0,423	1,057/0,423	1,269/0,529	1,586/0,846	1,586/0,846
Consumo G30 nom./rid. Consumption G30 nom./red.	Kg/h	0,654/0,256	0,788/0,315	0,788/0,315	0,946/0,394	1,182/0,630	1,182/0,630
Consumo G31 nom./rid. Consumption G31 nom./red.	Kg/h	0,644/0,256	0,776/0,310	0,776/0,310	0,931/0,388	1,164/0,621	1,164/0,621
Pressione nom. alimentazione G20/G31 Pressure nom. supply G20/G31	mbar	20 / 28-30/37	20 / 28-30/37	20 / 28-30/37	20 / 28-30/37	20 / 28-30/37	20 / 28-30/37
Pressione nom. ugelli G20/G31 Pressure nom. nozzles G20/G31	mbar	10,9 / 28,6/36,5	11,1 / 28,6/36,5	11,1 / 28,6/36,5	10,1 / 28,6/36,5	11 / 28,6/36,5	11 / 28,6/36,5
Pressione nom. ugelli G20/G31 rid. Pressure nom. nozzles G20/G31 red.	mbar	2/4,9-6,3	2/5,6-7,4	2/5,6-7,4	2/3,3-4,0	3/9-11	3/9-11
Diametro ugello bruciatore G20/G31 Diameter burner nozzle G20/G31	mm	2,5/1,45	2,9/1,6	2,9/1,6	2,3/1,25	2,5/1,4	2,5/1,4
Ugello bruciatore Burner nozzle	nr.	1	1	1	2	2	2
Ugello pilota G20/G30-G31 Pilot nozzle G20/G30-G31	code	0,35/0,25	0,35/0,25	0,35/0,25	0,35/0,25	0,35/0,25	0,35/0,25
Alimentazione Power supply	V	230VAC / 6VCC	230VAC / 6VCC	230VAC / 6VCC	230VAC / 6VCC	230VAC / 6VCC	230VAC / 6VCC
Potenza assorbita Power input	W	0	0	0	0	0	0
Diametro tubo attacco gas Diameter gas connection pipe	mm	3/8" - Ø10	3/8" - Ø10	3/8" - Ø10	3/8" - Ø10	3/8" - Ø10	3/8" - Ø10
Diametro tubo valvola bruciatore (L max: 1m) Diameter gas valve to burner supply pipe	mm	9V PP3	9V PP3	9V PP3	9V PP3	9V PP3	9V PP3
Batterie telecomando Remote control battery	type	1,5V AA	1,5V AA	1,5V AA	1,5V AA	1,5V AA	1,5V AA
Protezione Electrical protection		IP20	IP20	IP20	IP20	IP20	IP20
Categoria gas Gas category		3 _P -30, 3 _{B/P} -37, 3 _{B/P} -50, 3 ₊ , 2 _H , 2 _E , 2 _{E(R)} , 2 _{Er}	3 _P -30, 3 _{B/P} -37, 3 _{B/P} -50, 3 ₊ , 2 _H , 2 _E , 2 _{E(R)} , 2 _{Er}	3 _P -30, 3 _{B/P} -37, 3 _{B/P} -50, 3 ₊ , 2 _H , 2 _E , 2 _{E(R)} , 2 _{Er}	3 _P -30, 3 _{B/P} -37, 3 _{B/P} -50, 3 ₊ , 2 _H , 2 _E , 2 _{E(R)} , 2 _{Er}	3 _P -30, 3 _{B/P} -37, 3 _{B/P} -50, 3 ₊ , 2 _H , 2 _E , 2 _{E(R)} , 2 _{Er}	3 _P -30, 3 _{B/P} -37, 3 _{B/P} -50, 3 ₊ , 2 _H , 2 _E , 2 _{E(R)} , 2 _{Er}
Diametro tubo scarico STANDARD / ACCESSORIO STANDARD / OPTIONAL flue line	mm	MIN 180	MIN 180	MIN 180	MIN 180	MIN 180	MIN 180
Peso netto Net weight	Kg	6	7	10	15	19	21
Peso lordo Gross weight	Kg	7	8,5	12	17,5	22	24
Imballo L x L x h packaging L x W x h	cm	69 x 32 x 18	82 x 32 x 18	109 x 32 x 18	162 x 32 x 18	217 x 32 x 18	188 x 51 x 18



